

Series 23B, 123LP, N250, N250B

Water Pressure Reducing Valves

Installation Instructions

Install Valve in the line with arrow on valve body pointing in the direction of flow.

This valve should be installed where it is accessible with sufficient clearance for cleaning, service or adjustment. Install the reducing valve, when possible, before the sill cock line as shown in diagram. Before installing the reducing valve, flush out the line to remove loose dirt and scale which might damage valve disc and seat.

Horizontal installation is recommended. However, valve can be installed in a vertical position. Regulator must be installed in an accessible location to facilitate servicing the regulator.

To readjust reduced pressures, loosen adjusting screw nut and turn adjusting screw clockwise to raise reduced pressure and counterclockwise to lower reduced pressure.

When reducing valve is used, it makes a closed system; therefore, pressure relief protection must be provided on the downstream side of the reducing valve to protect equipment.

CAUTION: Anytime a reducing valve is adjusted, the use of a pressure gauge is recommended to verify correct pressure setting. Do not bottom out adjusting screw or spring cage.

Servicing

This series is a new development for standard capacity domestic water regulation service. It has special unitized construction which consists of the seat, disc and stem assembly, and strainer screen all together in one unit for complete replacement maintenance.

To clean or replace parts.

1. Remove spring cage and all parts above diaphragm.
2. Loosen and remove diaphragm lock nut, lock washer, pressure plate, and diaphragm from valve stem.
3. Unscrew seat cylinder from body and remove entire assembly. For diaphragm replacement only, see part number.
4. While disassembled open gate valve to flush out collected sediment.

NOTE: Cast iron body regulators (N250/N250B) are not intended for buried or pit services.

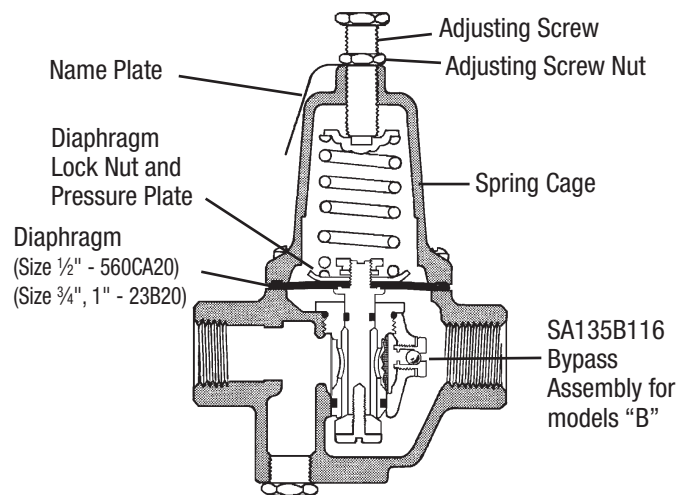
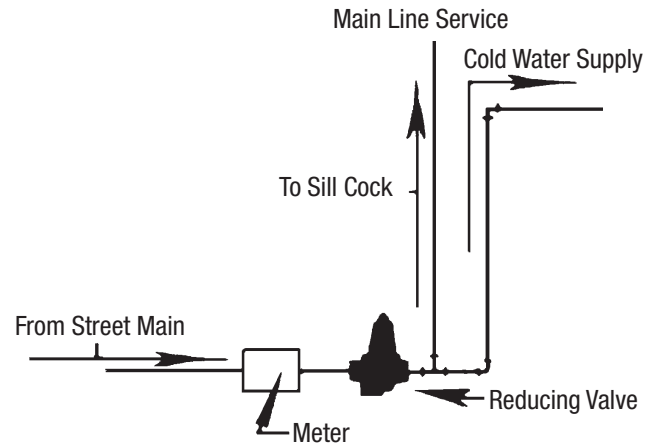

Complete Replacement Assembly

See reverse side for ordering information

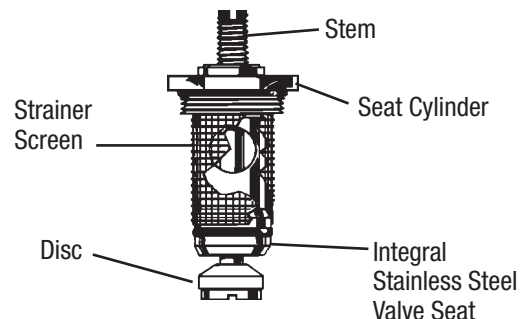

CALIFORNIA PROPOSITION 65 WARNING

WARNING: This product contains chemicals known to the State of California to cause cancer and birth defects or other reproductive harm. (California law requires this warning to be given to customers in the State of California.)

For more information: www.watts.com/prop65

WATTS®

Series 23, 123, N250

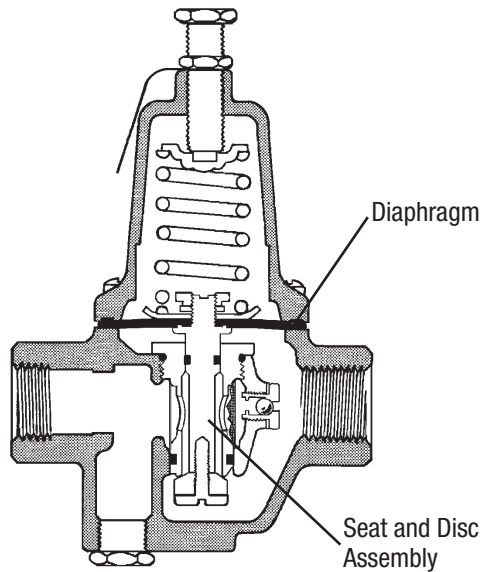

Complete Replacement Assembly
(Includes Diaphragm)

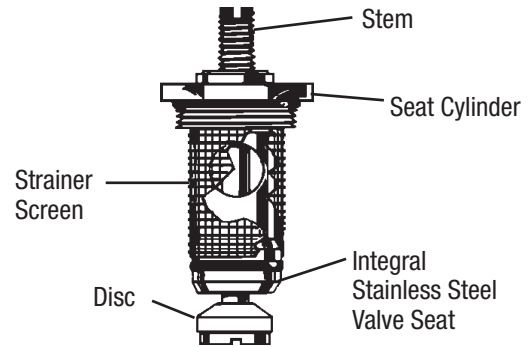

When Ordering, Specify:

1. Ordering Code Number
2. Size of Valve
3. Type Number
4. Model Shown on Nameplate

Kit for No. 23, 123, N250, N250B includes all items shown.

Ordering Code No.	Kit No.	Valve Series	Size Inches
878377	1/2" N250RK	23, 123, N250	1/2
878339	3/4" N250RK	23, 123, N250, N256	3/4

What is - thermal expansion?

The use of a water pressure reducing valve normally creates a closed system. When water is heated in a closed system, it expands causing an increase in pressure. This pressure may increase to the set pressure of the relief valve (on the water heater) causing it to drip, thus releasing the expanding water and protecting the system against excessive pressure. This increase in the system pressure over that regulated by the reducing valve is called "thermal expansion pressure".

Watts thermal expansion bypass model water pressure reducing valve is an economical solution of this annoyance, since under certain conditions it allows the expanding water to escape back into the supply main before it can affect the relief valve.

Watts Thermal Expansion "Bypass" model water pressure reducing valves not only control high water service pressure but also contain an "integral thermal expansion bypass check valve" which reduces the frequency of relief valve dripping caused by thermal expansion.

The built-in thermal expansion bypass, another Watts first, operates on the principle of a check valve in reverse. Normally, the check is held closed by the street main pressure, preventing any flow of water through it into the system. However, when thermal expansion pressure increases to just 1 lb. to 2 lbs. higher than the main pressure, the check valve opens passing the expanding water back into the supply main at the rate it is expanded. Thus, the expanding water is dissipated (as in an open system) and the relief valve is not affected.

***Note:** Effectiveness of the thermal expansion bypass feature is limited to systems where the street main pressure is less than the allowable setting of the pressure relief valve. Therefore, its use can be broadened by using a relief valve with higher pressure setting (providing the working pressure of the tank permits). While this feature limits the conditions causing relief valve dripping, it in no way replaces a pressure relief valve which is necessary to protect against other causes of excessive pressure.

NOTE: For additional detailed information on thermal expansion send for folder F-RV.

LIMITED WARRANTY: Watts Regulator Co. (the "Company") warrants each product to be free from defects in material and workmanship under normal usage for a period of one year from the date of original shipment. In the event of such defects within the warranty period, the Company will, at its option, replace or recondition the product without charge.

THE WARRANTY SET FORTH HEREIN IS GIVEN EXPRESSLY AND IS THE ONLY WARRANTY GIVEN BY THE COMPANY WITH RESPECT TO THE PRODUCT. THE COMPANY MAKES NO OTHER WARRANTIES, EXPRESS OR IMPLIED. THE COMPANY HEREBY SPECIFICALLY DISCLAIMS ALL OTHER WARRANTIES, EXPRESS OR IMPLIED, INCLUDING BUT NOT LIMITED TO THE IMPLIED WARRANTIES OF MERCHANTABILITY AND FITNESS FOR A PARTICULAR PURPOSE.

The remedy described in the first paragraph of this warranty shall constitute the sole and exclusive remedy for breach of warranty, and the Company shall not be responsible for any incidental, special or consequential damages, including without limitation, lost profits or the cost of repairing or replacing other property which is damaged if this product does not work properly, other costs resulting from labor charges, delays, vandalism, negligence, fouling caused by foreign material, damage from adverse water conditions, chemical, or any other circumstances over which the Company has no control. This warranty shall be invalidated by any abuse, misuse, misapplication, improper installation or improper maintenance or alteration of the product.

Some States do not allow limitations on how long an implied warranty lasts, and some States do not allow the exclusion or limitation of incidental or consequential damages. Therefore the above limitations may not apply to you. This Limited Warranty gives you specific legal rights, and you may have other rights that vary from State to State. You should consult applicable state laws to determine your rights. SO FAR AS IS CONSISTENT WITH APPLICABLE STATE LAW, ANY IMPLIED WARRANTIES THAT MAY NOT BE DISCLAIMED, INCLUDING THE IMPLIED WARRANTIES OF MERCHANTABILITY AND FITNESS FOR A PARTICULAR PURPOSE, ARE LIMITED IN DURATION TO ONE YEAR FROM THE DATE OF ORIGINAL SHIPMENT.



Water Safety & Flow Control Products



USA: 815 Chestnut St., No. Andover, MA 01845-6098; www.watts.com

Canada: 5435 North Service Rd., Burlington, ONT. L7L 5H7; www.wattscanada.ca